The background features a gradient from red at the top to blue at the bottom, overlaid with faint, semi-transparent mathematical diagrams. These include circular arcs, dashed lines, and arrows, some resembling a coordinate system or a complex geometric construction. A starry space pattern is visible in the lower right portion of the image.

THINGS THAT USED TO BE STRANGE  
ARE FAMILIAR NOW:  
REFLECTIONS ON THE INEVITABLE EVOLUTION OF  
PEDAGOGY & SCHOLARSHIP

**DR. OMAYRA ORTEGA**

SONOMA STATE UNIVERSITY

BLACKWELL TAPIA CONFERENCE  
MATHEMATICAL SCIENCES RESEARCH INSTITUTE

NOVEMBER 20, 2021



# THE SPUTNIK CRISIS

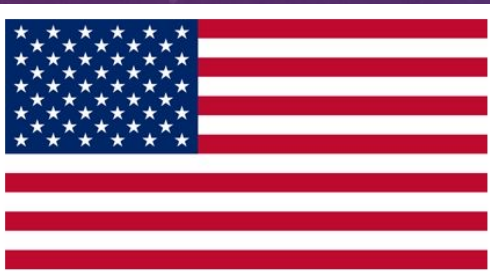
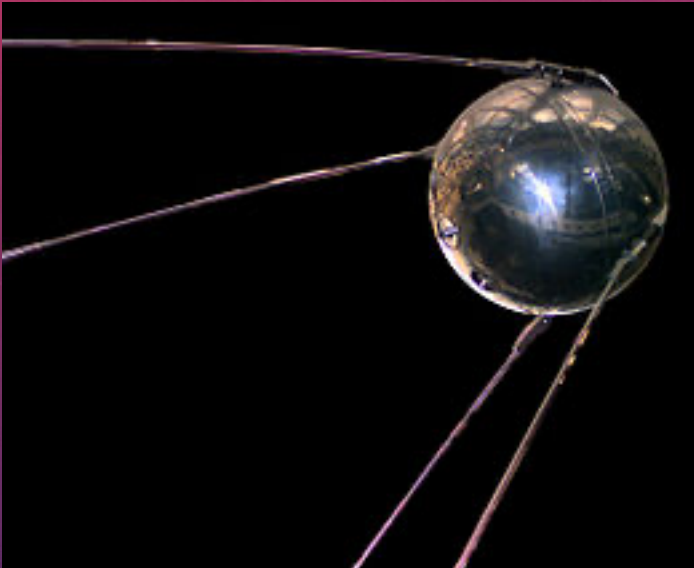

## SOVIET FIRES EARTH SATELLITE INTO SPACE; IT IS CIRCLING THE GLOBE AT 18,000 M. P. H.; SPHERE TRACKED IN 4 CROSSINGS OVER U. S.

**HUFFA IS ELECTED TEAMSTERS' HEAD; WARNS OF BATTLE**  
 Defeats Two Rivals in 1—Says Fight Will Fight "With Every Gun"

John P. Huffa, 50, of Buffalo, N. Y., was elected president of the International Brotherhood of Teamsters, Local Union No. 1, in a vote of 1,000 to 700 over two other candidates. Huffa, who has been in the union for 15 years, said he would lead the union in a fight against the National Labor Relations Board.

**COURSE RECORDED**  
 Navy Picks Up Radio Signals—4 Report Sighting Device

Four Navy ships, including the USS Albatross (AG-42), reported picking up radio signals from the Soviet satellite in space. The signals were identified as being from the satellite, which is believed to be the first of a series of satellites to be launched by the Soviet Union.



**500 MILES HIGH**  
 Visible With Simple Binoculars, Moscow Statement Says

**Device Is 8 Times Heavier Than One Planned by U. S.**

**SATELLITE SIGNAL BROADCAST HERE**

**Impulse Carried on Radio and TV—First Reported by Long Island Station**

**U. S. Scientists Say Satellite Is 8 Times Heavier Than One Planned by U. S.**

**FALGUS COMPARES 1957 Rate Predicted, 200,000 Pupils One**

**ARGENTINA TAKES EMERGENCY STEPS**

**State of Emergency Declared in Buenos Aires Region—Armed Reported**

**Ex-Premier Mollat Accepts Bid To Form a New French Cabinet**

**Swiss Labor Agrees With Relations and Will Go on Strike**

**Waraw Crushes New Protest; Clubs, Tear Gas Rout Students**



**WARSAW CRUSHES NEW PROTEST; CLUBS, TEAR GAS ROUT STUDENTS**  
 A group of about 500 students gathered in the city of Warsaw for a protest against the government. The police used clubs and tear gas to disperse the crowd.

**WIFE OF VICTIM**—Dora Smith, widow of the Transamerica office manager who was killed in the explosion at the office of the firm, is seen with her children.

**WIFE OF VICTIM**—Dora Smith, widow of the Transamerica office manager who was killed in the explosion at the office of the firm, is seen with her children.

**WIFE OF VICTIM**—Dora Smith, widow of the Transamerica office manager who was killed in the explosion at the office of the firm, is seen with her children.

**WIFE OF VICTIM**—Dora Smith, widow of the Transamerica office manager who was killed in the explosion at the office of the firm, is seen with her children.

**WIFE OF VICTIM**—Dora Smith, widow of the Transamerica office manager who was killed in the explosion at the office of the firm, is seen with her children.

**WIFE OF VICTIM**—Dora Smith, widow of the Transamerica office manager who was killed in the explosion at the office of the firm, is seen with her children.

**WIFE OF VICTIM**—Dora Smith, widow of the Transamerica office manager who was killed in the explosion at the office of the firm, is seen with her children.

**WIFE OF VICTIM**—Dora Smith, widow of the Transamerica office manager who was killed in the explosion at the office of the firm, is seen with her children.

**WIFE OF VICTIM**—Dora Smith, widow of the Transamerica office manager who was killed in the explosion at the office of the firm, is seen with her children.

**THE NEW MATHEMATICS**

*Irving Adler*

**A PARENT'S GUIDE TO THE NEW MATHEMATICS • Evelyn Sharp**



P  
2815

**THE "NEW" MATH • BARKER, CURRAN, METCALF**

**A Fawcett Premier Book**

**FUN WITH THE NEW MATH** *Meyer & Hanlon*

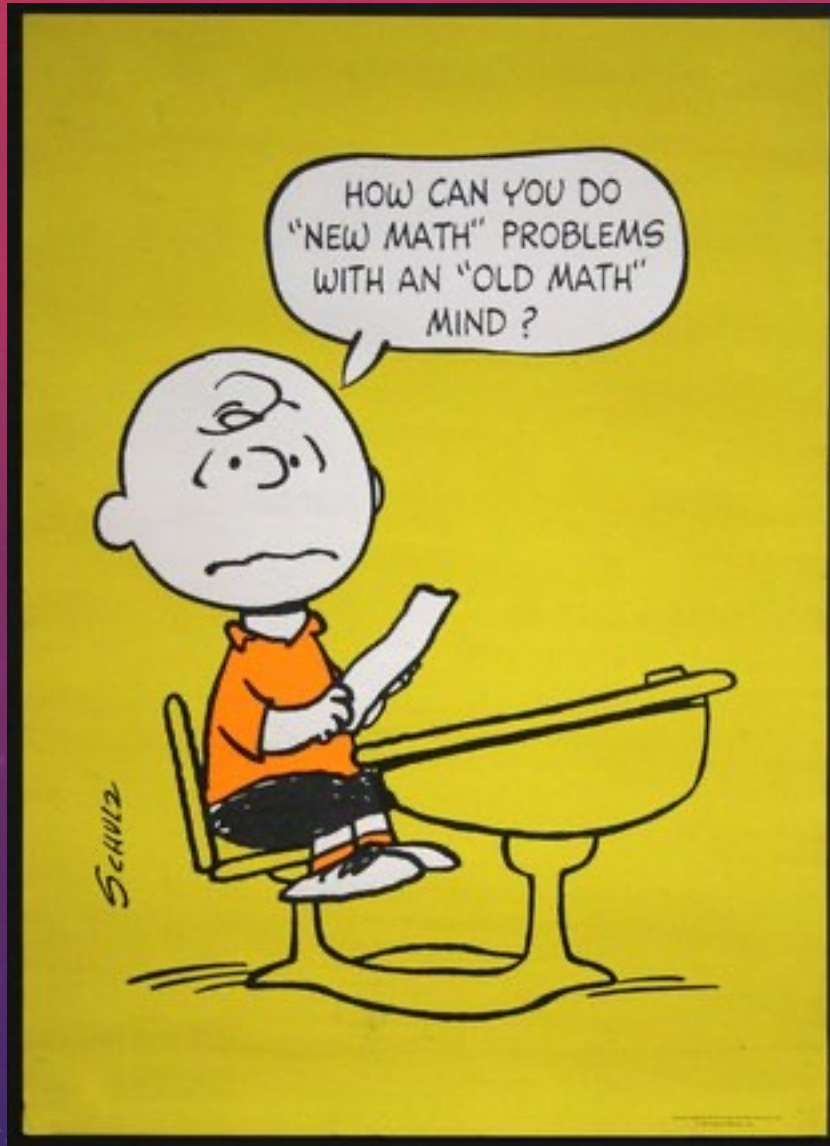

# THE NEW MATH

- Set theory,
- Modular arithmetic,
- Algebraic inequalities,
- Bases other than 10,
- Matrices,
- Symbolic logic,
- Boolean algebra, and
- Abstract algebra.

**NEW  
HOO  
HOO  
MATH**



# THE COMMON CORE

## GOALS

- Eliminate disparities in education and,
- Equip students for success in careers and higher education.

Common core instruction is based on three major principles:  
**focus, coherence, & rigor**

**PROBLEM 1**

Solve this problem:

$$\begin{array}{r} 199 \\ + 87 \\ \hline \end{array}$$

Traditional solution with algorithm

$$\begin{array}{r} 1\ 199 \\ + 87 \\ \hline 286 \end{array}$$

Understanding number composition

$$199 + 87$$

(Move 1 from the 87 to the 199)

$$200 + 86 = 286$$

**PROBLEM 2**

Solve this problem:

$$\begin{array}{r} 25 \\ \times 12 \\ \hline \end{array}$$

Understanding number composition

$$25 \times 12 = 25 \times 4 \times 3 = 100 \times 3 = 300$$

(12 is three 4's) (Four 25's are 100)

**PROBLEM 3**

Solve this problem:

$$198 \times 5$$

Understanding number composition

$$198 \times 5 = 1000 - 10 = 990$$

(198 is 2 away from 200) (5 x 200 = 1000) (5 x 2 = 10)

# Common Core State Standards Development Timeline

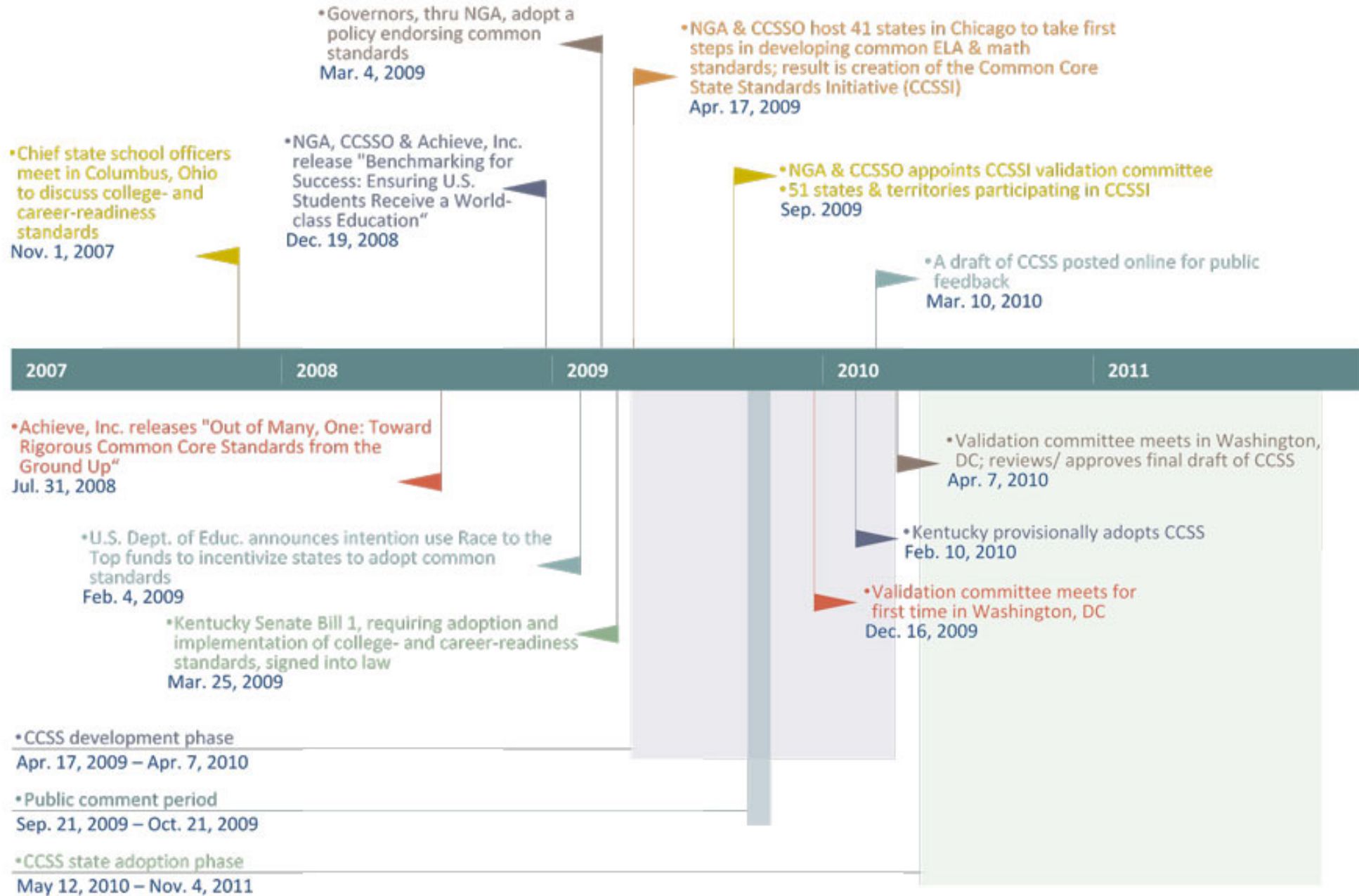





# CALIFORNIA MATHEMATICS FRAMEWORK

- Revisions are made to the California Mathematics Framework every 8 years.
- Optional guidelines for districts to use
- Selected guidelines:
  - Testing for math pathway placement moved from 4<sup>th</sup> grade to 8<sup>th</sup> grade
  - High school **data science** course
  - Prioritize student engagement
  - Access to an engaging and humanizing education
  - Everyone is capable of learning

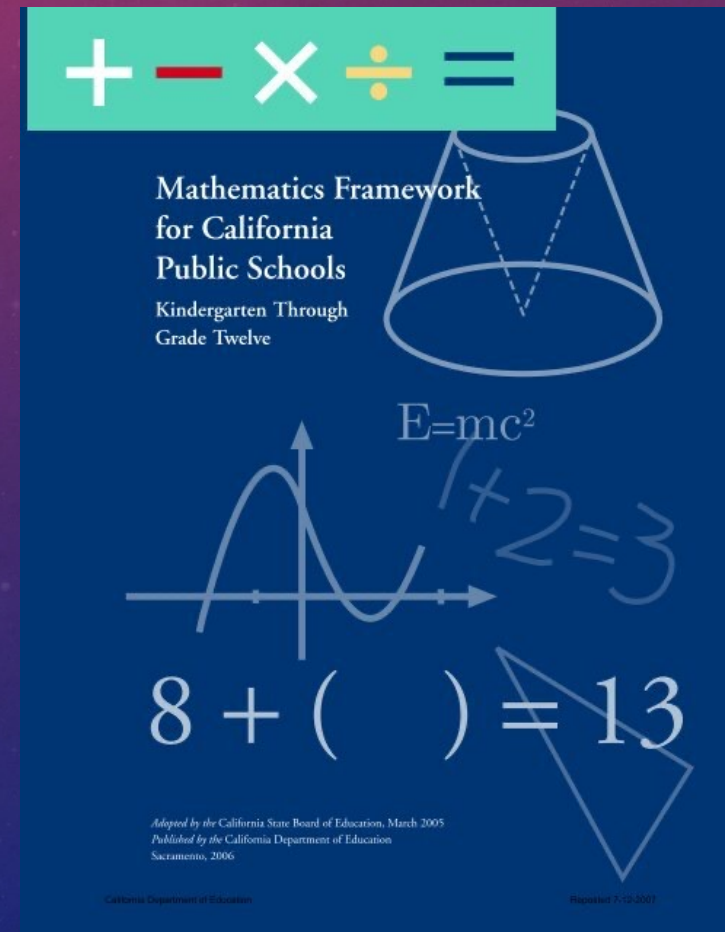

# CALIFORNIA MATHEMATICS FRAMEWORK

“People will really go to battle for maths to stay the same,” said Jo Boaler, a professor of education at Stanford University who is working on the revision. “Even parents who hated maths in school will argue to keep it the same for their kids.”

-Dr. Jo Boaler, Stanford University



# MATHEMATICS AS A GATEKEEPER

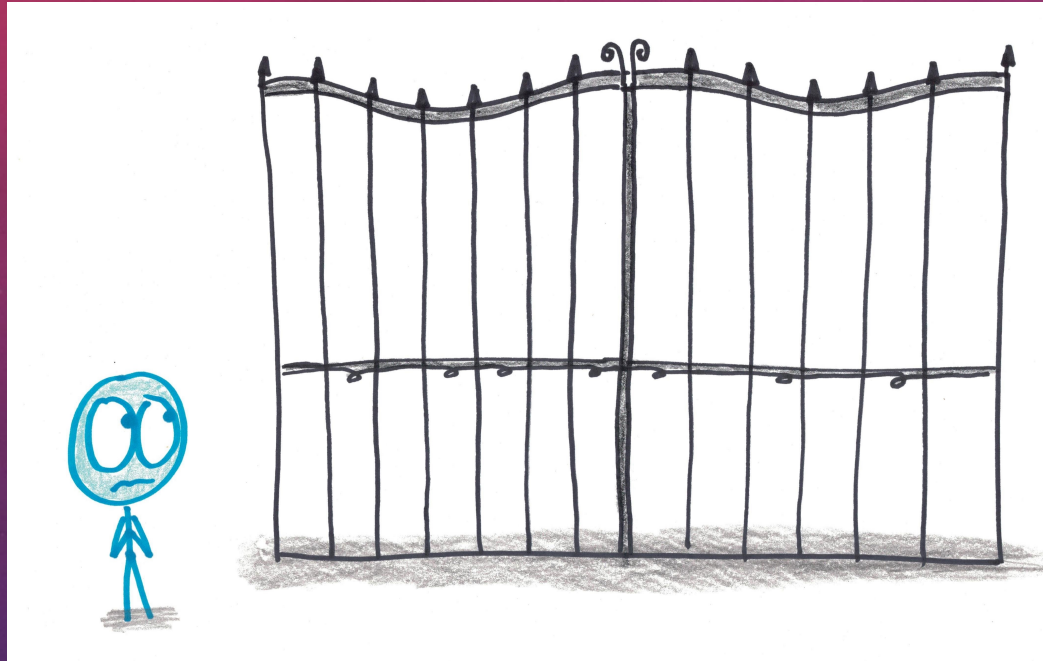

[www.mathwithbaddrawings.com](http://www.mathwithbaddrawings.com)

ἀγεωμέρητος  
μηδείς  
εἰσίτω

Algebra

Geometry

Algebra 2

Pre-  
Calculus

Calculus

# THE ALGEBRA PROJECT

- The Algebra Project uses mathematics literacy as an organizing tool to guarantee quality public school education for all children in the United States of America.

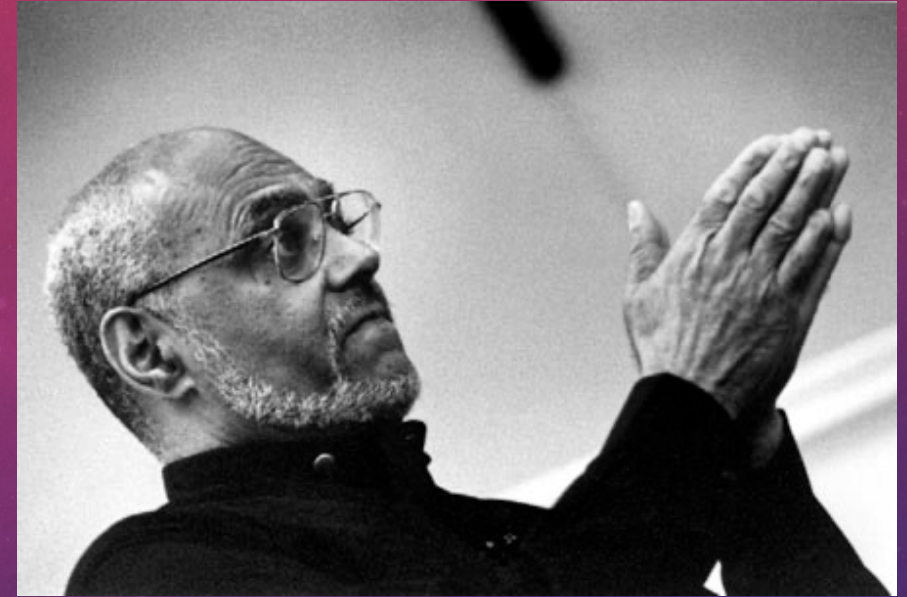

# COMMONALITIES ACROSS THESE INITIATIVES

- Goal to improve student outcomes
  - Especially for underserved students
- Heavy teacher involvement
- Drastic changes to textbook publishing
- Required government funds
- Highlighted generation gaps in families and communities
- Met with backlash from some
- Politicians used education to further their political aims
- Introduce new pedagogy and new scholarship

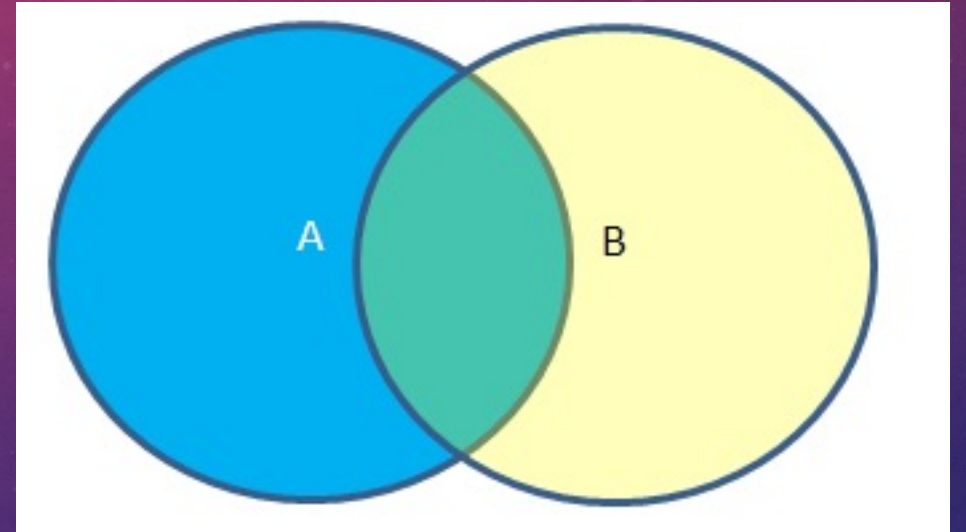



# EDUCATORS HOLD AN IMPORTANT ROLE

- Cult of the genius
- Observer-expectancy effect
- Implicit bias
- Microaggressions
- Blatant racism



# TRANSFORMATIVE INCLUSION IN POST-SECONDARY EDUCATION

- Department as the unit of treatment
- Professional development
- Lesson study
- Reflection
- Implementation

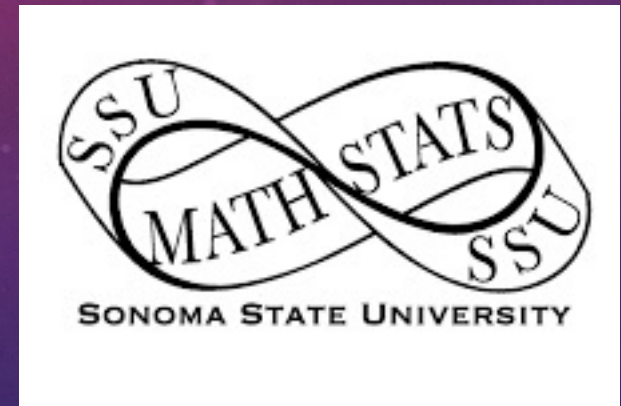



It is never easy to demand the most from ourselves, from our lives, from our work. To encourage excellence is to go beyond the encouraged mediocrity of our society is to encourage excellence.

**AUDRE LORDE**

FEMINIST, WRITER, AND CIVIL RIGHTS  
ACTIVIST.

[forcreativegirls.com](http://forcreativegirls.com)

# MATH IS A LANGUAGE



- Vocabulary
- Grammar
- Syntax

*Students need to be prepared through their mathematics education to investigate and critique injustice, and to challenge, in words and actions, oppressive structures and acts – that is, to “read and write” the world with mathematics.*

**Dr. Eric Gutstein**

*Reading and Writing the World with Mathematics*

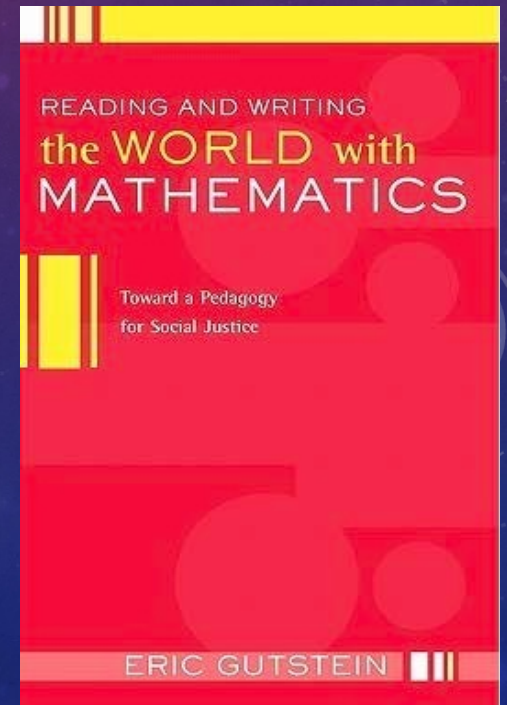

78,139 NEGROES IN CITIES  
OF OVER 10,000 INHABITANTS

8,025 NEGROES IN CITIES  
FROM 5,000 TO 10,000

37,699  
NEGROES  
IN CITIES  
FROM  
2,500 TO 5,000

734,952

NEGROES LIVING IN THE COUNTRY AND VILLAGES.

Close up on Atlanta University's "City and Rural Population. 1890" data visualization (Public Domain)

“It is not one problem, but rather a plexus of social problems, some new, some old, some simple, some complex; and these problems have their one bond of unity in the act that they group themselves above those Africans whom two centuries of slave-trading brought into the land.”

-WEB DuBois

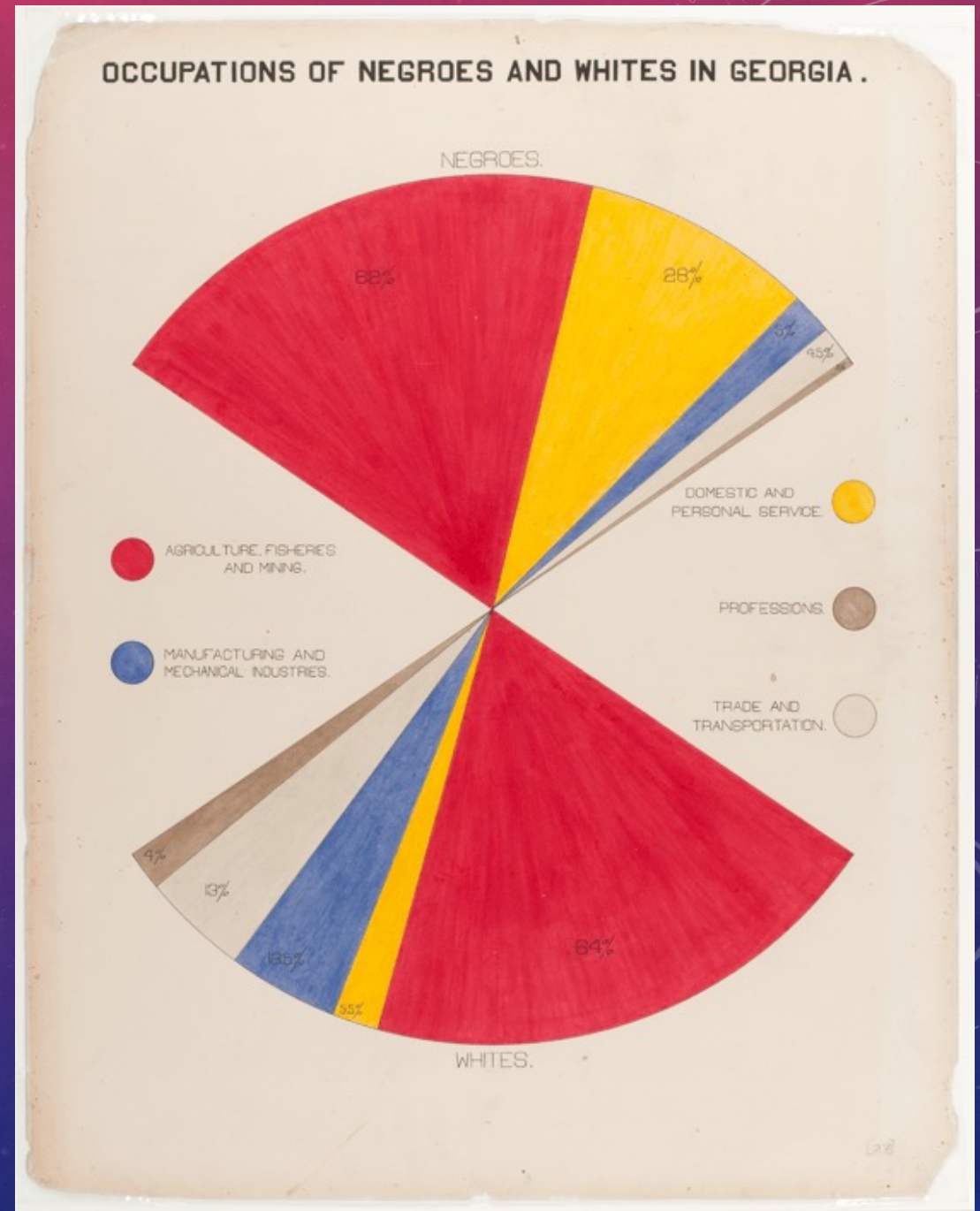

Comparing Occupations by Race

PROPORTION OF FREEMEN AND SLAVES AMONG AMERICAN NEGROES .

PROPORTION DES NÈGRES LIBRES ET DES ESCLAVES EN AMÉRIQUE .

DONE BY ATLANTA UNIVERSITY .

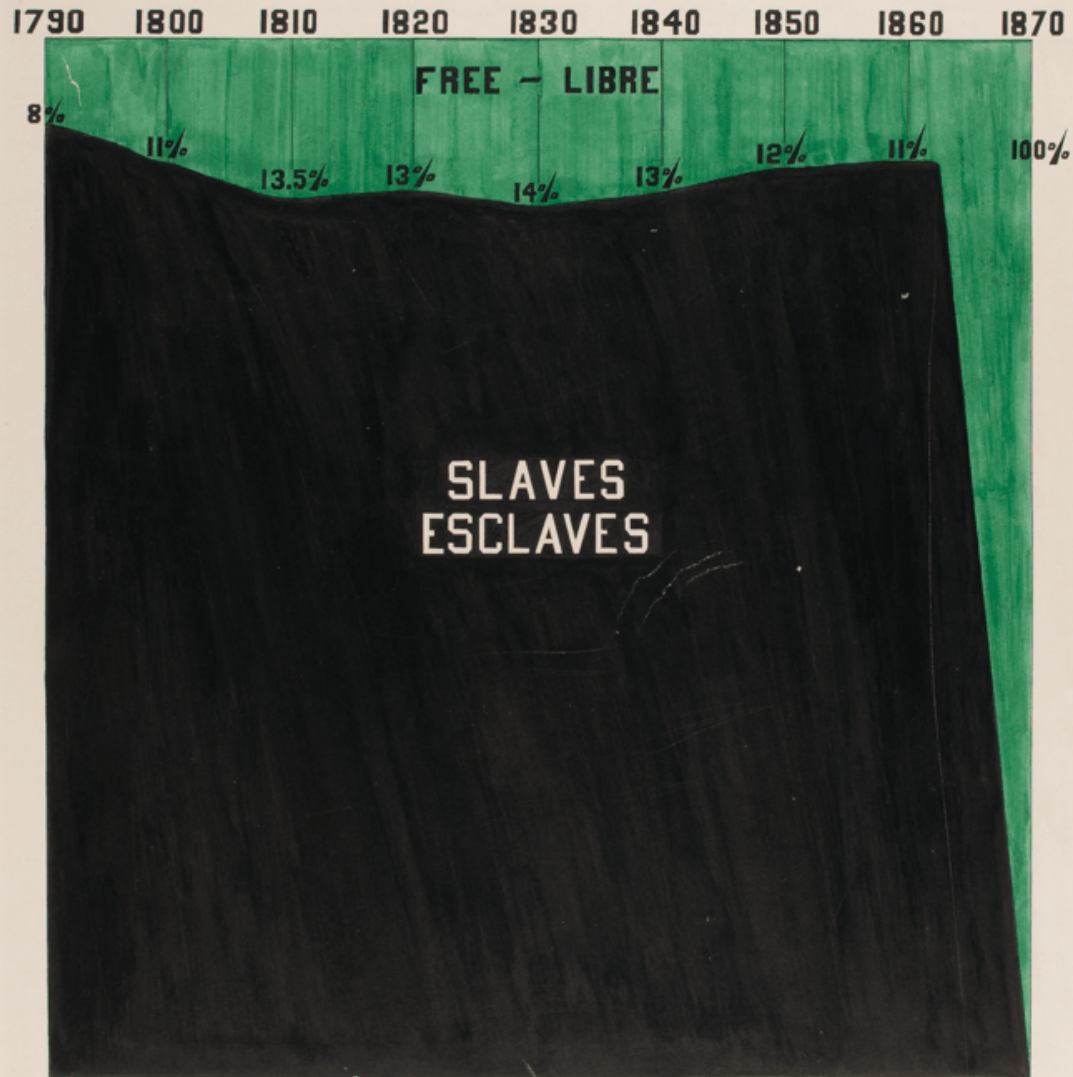

### SLAVES AND FREE NEGROES.

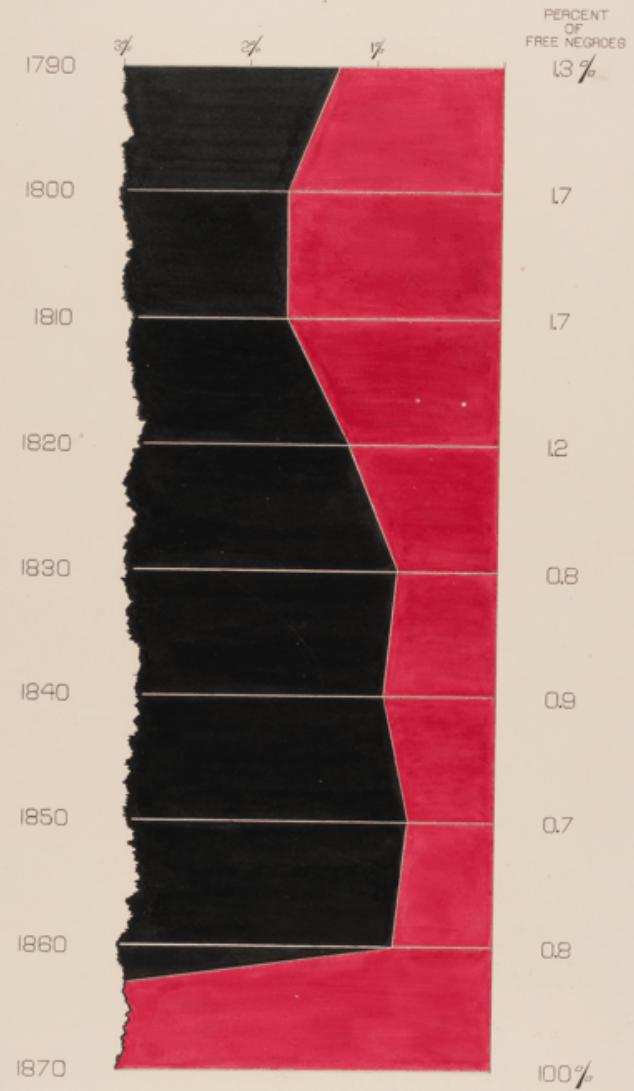

# DIFFERENTIAL EQUATIONS

$$\frac{dS}{dt} = -\beta[I(t) + \eta_A A(t) + \eta_Q Q(t) + \eta_H H(t)]S(t)$$

$$\frac{dE}{dt} = \beta[I(t) + \eta_A A(t) + \eta_Q Q(t) + \eta_H H(t)]S(t) - \sigma E(t)$$

$$\frac{dA}{dt} = q\sigma E(t) - (\gamma_A + \delta_A)A(t)$$

$$\frac{dI}{dt} = (1-q)\sigma E(t) + \nu_Q Q(t) + \nu_H H(t) - (\omega_Q + \omega_H + \gamma_I + \delta_I)I(t)$$

$$\frac{dQ}{dt} = \omega_Q I(t) - (\nu_Q + \gamma_Q + \delta_Q)Q(t)$$

$$\frac{dH}{dt} = \omega_H I(t) - (\nu_H + \gamma_H + \delta_H)H(t)$$

$$\frac{dR}{dt} = (\gamma_A + \delta_A)A(t) + (\gamma_I + \delta_I)I(t) + (\gamma_Q + \delta_Q)Q(t) + (\gamma_H + \delta_H)H(t)$$

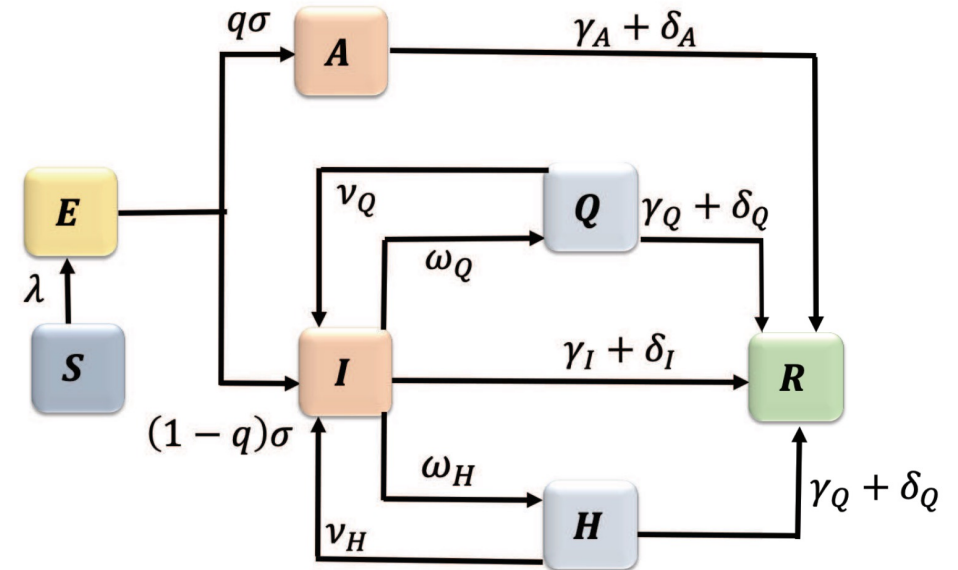



# BASIC REPRODUCTIVE NUMBER

average number of secondary infections  
produces by a single infectious person in a  
totally susceptible population

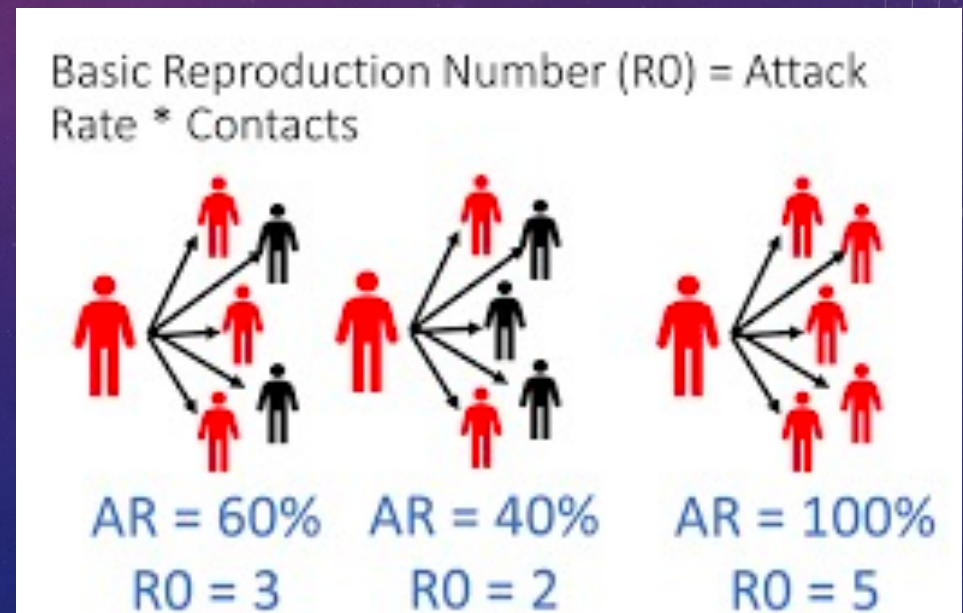

# ROLE OF QUARANTINED AND HOSPITALIZED INDIVIDUALS

Increasing quarantine and hospitalization rates decreases the disease burden and reduces the epidemic peak.

Moreover, these measures postpone the peak of the infection, thus giving more time to prepare for the coming spike of the disease.

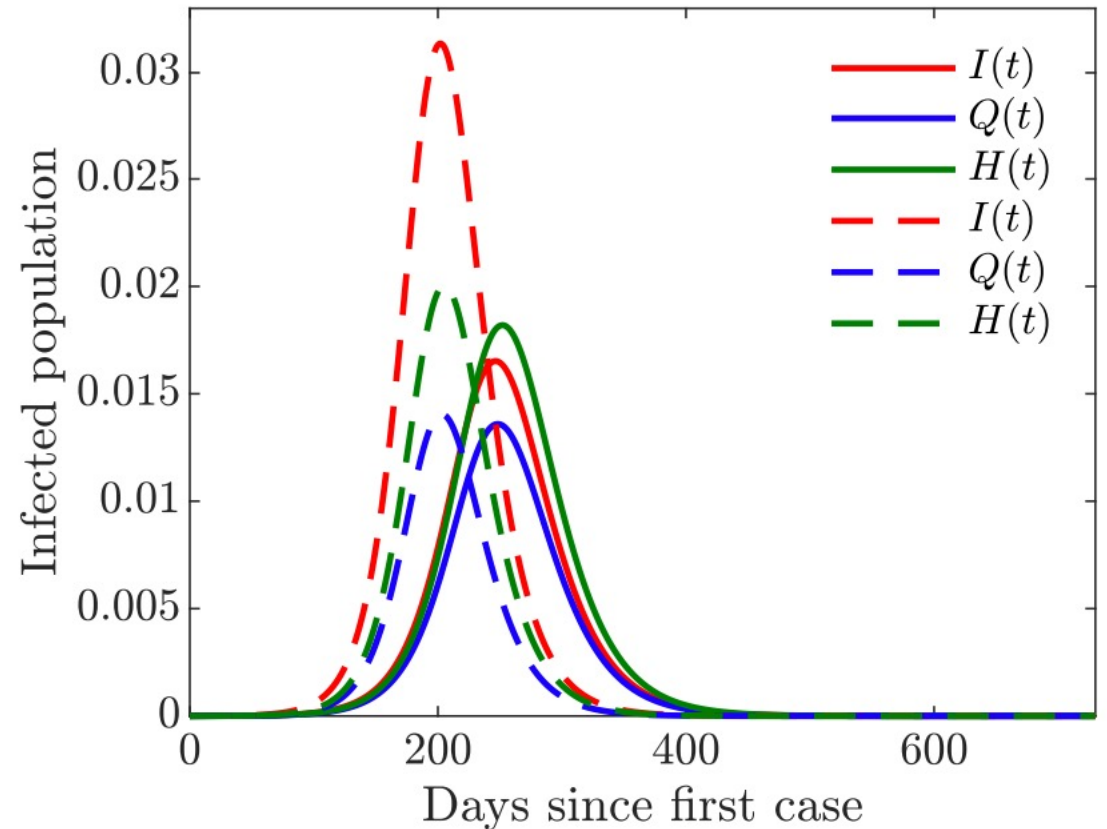

# COVID-19 CASES, HOSPITALIZATION, AND DEATH BY RACE/ETHNICITY

## FACTORS THAT INCREASE COMMUNITY SPREAD AND INDIVIDUAL RISK



CROWDED SITUATIONS



CLOSE / PHYSICAL CONTACT



ENCLOSED SPACE



DURATION OF EXPOSURE

Rate ratios compared to White, Non-Hispanic Persons	American Indian or Alaska Native, Non-Hispanic persons	Asian, Non-Hispanic persons	Black or African American, Non-Hispanic persons	Hispanic or Latino persons
CASES <sup>1</sup>	2.8x higher	1.1x higher	2.6x higher	2.8x higher
HOSPITALIZATION <sup>2</sup>	5.3x higher	1.3x higher	4.7x higher	4.6x higher
DEATH <sup>3</sup>	1.4x higher	No Increase	2.1x higher	1.1x higher

Race and ethnicity are risk markers for other underlying conditions that impact health — including socioeconomic status, access to health care, and increased exposure to the virus due to occupation (e.g., frontline, essential, and critical infrastructure workers).

## ACTIONS TO REDUCE RISK OF COVID-19



WEARING A MASK



SOCIAL DISTANCING (6 FT GOAL)



HAND HYGIENE



CLEANING AND DISINFECTION



<sup>1</sup> Data source: COVID-19 case-level data reported by state and territorial jurisdictions. Case-level data include about 80% of total reported cases. Numbers are unadjusted rate ratios.

<sup>2</sup> Data source: COVID-NET (<https://www.cdc.gov/coronavirus/2019-ncov/covid-data/covidview/index.html>, accessed 08/06/20). Numbers are ratios of age-adjusted rates.

<sup>3</sup> Data source: NCHS Provisional Death Counts (<https://www.cdc.gov/nchs/nvss/vsrr/COVID19/index.htm>, accessed 08/06/20). Numbers are unadjusted rate ratios.

[cdc.gov/coronavirus](https://cdc.gov/coronavirus)

“Remember, whatever discipline you're in  
Whether you're a musician or a photographer  
A fine artist or a cartoonist, a writer, a dancer  
A singer, a designer — whatever you do  
You have one thing that's unique  
You have the ability to make art. Sometimes life is hard  
Things go wrong — in life and in love  
And in business and in friendship and in health  
And when things get tough, this is what you should do  
Make good art”

-Neil Gaiman



# Thank you

ortegao@sonoma.edu

