

# A knot Floer stable homotopy type

Ciprian Manolescu  
*based on joint work with Sucharit Sarkar*

November 17, 2022

**Floer homotopy theory** aims to construct spaces (or stable homotopy types) whose homology is Floer homology:

- 1 **Cohen-Jones-Segal** (1995): sketch of the general procedure;
- 2 **M.** (2001), **Kronheimer-M.** (2002), **Khandhawit-Lin-Sasahira** (2016), **Sasahira-Stoffregen** (2021): Seiberg-Witten Floer homotopy for 3-manifolds;
- 3 **Cohen** (2007): Hamiltonian Floer homotopy type of  $T^*M$ ;
- 4 **Lipshitz-Sarkar** (2011): Khovanov homotopy type for knots in  $\mathbb{R}^3$ ;
- 5 **Abouzaid-Blumberg** (2021): Hamiltonian Morava K-theory  $\rightarrow$  Arnol'd conjecture over  $\mathbb{F}_p$ .
- 6 *Other versions of Floer theory*: work in progress of many people.

# Link Floer homology

**This talk:** To a grid diagram  $\mathbb{G}$ , we will associate a stable homotopy type whose homology is grid homology (link Floer homology).

**Ozsváth-Szabó, Rasmussen, 2003:** *knot Floer homology*  $HFK =$  bigraded homology theory for knots. Different versions:  $\widehat{HFK}$ ,  $HFK^-$ ,  $HFK^+$ , etc.

$\sum_{i,j} (-1)^i q^j \widehat{HFK}_i(K, j) = \Delta_K(q)$ , the Alexander polynomial

Generalization:  $HFL =$  *link Floer homology* (**Ozsváth-Szabó, 2005**)

**Sample applications:**

- 1 The genus of a knot

$$g(K) = \min\{g \mid \exists \text{ oriented } \Sigma^2 \subset S^3 \text{ of genus } g, \partial\Sigma = K\}$$

can be read from  $\widehat{HFK}$  (**Ozsváth-Szabó, 2004**):

$$g(K) = \max\{s \geq 0 \mid \exists m, \widehat{HFK}_m(S^3, K, s) \neq 0\}.$$

## Sample applications:

- ②  $\widehat{HFK}_*(S^3, K, g(K)) = \mathbb{Z} \iff S^3 - K$  fibers over  $S^1$  (**Ghiggini, Ni, Juhász**, 2006)
- ③  $\widehat{HFK}$  detects the unknot, trefoil and figure-eight knot;
- ④ (**Ozsváth-Szabó**, 2003) Bounds on  $g_4(K) = \min\{g \mid \exists \text{ oriented } \Sigma^2 \subset B^4 \text{ of genus } g, \partial\Sigma = K\}$ ;
- ⑤ Questions about surgery on knots.

**Combinatorial description:** *grid homology* (**M.-Ozsváth-Sarkar**, 2006), in terms of grid diagrams.

Different versions:  $\widehat{GH}$ ,  $GH^+$ ,  $GH^-$ , etc. We will focus on  $GH^+$ .

# Grid diagrams

Every link in  $S^3$  admits a *grid diagram*  $\mathbb{G}$ ; that is, an  $n$ -by- $n$  grid on the torus with  $O$  and  $X$  markings inside such that:

- Each row and each column contains exactly one  $X$  and one  $O$ ;
- As we trace the vertical and horizontal segments between  $O$ 's and  $X$ 's (verticals on top), we see the link  $L$ .

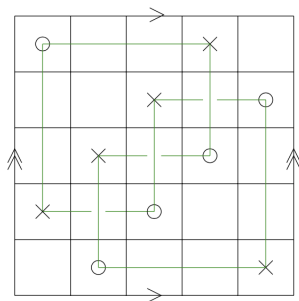

# States

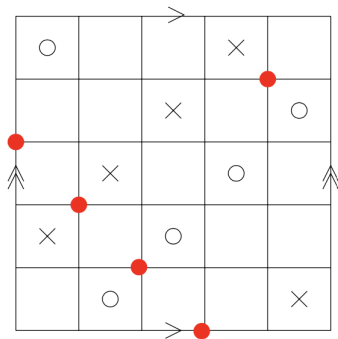

We define a state  $x = \{x_1, \dots, x_n\}$  to be an  $n$ -tuple of points on the grid (one on each vertical and horizontal circle). The set of states is denoted  $\mathbb{S}$ .

# Generators

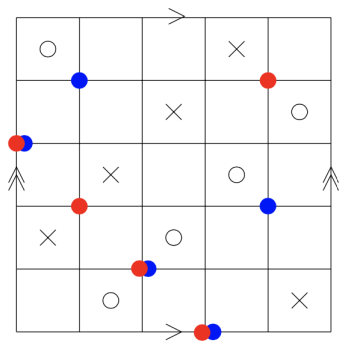

We define a state  $x = \{x_1, \dots, x_n\}$  to be an  $n$ -tuple of points on the grid (one on each vertical and horizontal circle). The set of states is denoted  $\mathbb{S}$ .

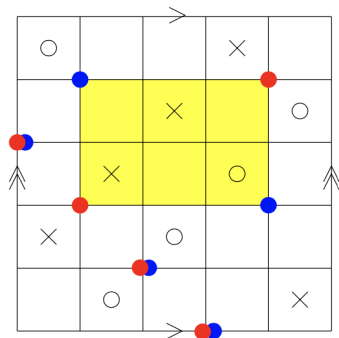

In a grid diagram  $\mathbb{G}$ , index 1 pseudo-holomorphic strips in  $\text{Sym}^n(\mathbb{G})$  are in 1-to-1 correspondence to empty rectangles on the grid (that is, having no red or blue dots inside).



# The grid complex

Different ways of keeping track of the  $O$  and  $X$  markings  $\rightsquigarrow$  different versions of the grid complex.

The version  $GC^+(\mathbb{G})$  is generated by

$$U_1^{-j_1} \dots U_n^{-j_n} x = [x, j_1, \dots, j_n], \quad x \in \mathbb{S}, \quad j_1, \dots, j_n \in \mathbb{N}$$

in homological grading  $\text{gr}(x) + 2j_1 + \dots + 2j_n$ .

The differential on  $GC^+$  is given by

$$\partial([x, j_1, \dots, j_n]) = \sum_y \sum_{\substack{R \in \mathcal{R}(x,y) \\ \mathbb{X}(R) = (0, \dots, 0)}} s(R) U^{\mathbb{O}(R)} [y, j_1, \dots, j_n],$$

where  $U^{\mathbb{O}(R)} := U_1^{O_1(R)} \dots U_n^{O_n(R)}$ .

The homology  $GH^+(\mathbb{G}) = GH^+(K) = HFL^+(K)$  is independent of  $\mathbb{G}$ .

Grid homology is an example of **Lagrangian Floer homology**:

$M = \text{Sym}^n(\mathbb{G})$  symplectic manifold;  $L_0 = \mathbb{T}_\alpha$ ,  $L_1 = \mathbb{T}_\beta$  Lagrangians

$\rightsquigarrow \mathcal{M}(x, y)$  moduli spaces of pseudo-holomorphic strips

$\rightsquigarrow (CF(L_0, L_1), \partial) \rightsquigarrow HF(L_0, L_1)$ . To have  $\partial^2 = 0$ , ideally we want

$$\partial \overline{\mathcal{M}}(x, y) = \coprod_z \overline{\mathcal{M}}(x, z) \times \overline{\mathcal{M}}(z, y).$$

In general, in symplectic geometry, the compactification  $\overline{\mathcal{M}}(x, y)$  has additional points, coming from **disk and sphere bubbles**. Thus, we may have  $\partial^2 \neq 0$ .

If we avoid at least one marking on the grid, then we do not have sphere bubbles. We may have disk bubbles, corresponding to rows and columns on the grid. We still have  $\partial^2 = 0$ , because the row through  $O_i$  cancels out the column through  $O_i$ . For  $GH^+$ , there are no disk bubbles either.

# The Spanier-Whitehead suspension category

*Objects* (suspension spectra): pairs  $(X, n) = \Sigma^{-n}X$ , where  $X =$  pointed CW complex,  $n \in \mathbb{Z}$ .

*Morphisms* are stable homotopy classes of maps:

$$\text{Hom}((X, n), (Y, m)) = \text{colim}_{q \rightarrow \infty} [\Sigma^{q-n}X, \Sigma^{q-m}Y].$$

e.g.  $(S^0, 5) = S^{-5}$  the “ $(-5)$ -dimensional sphere”

The (reduced) homology of  $(X, n)$  is  $\tilde{H}_i(X, n) = \tilde{H}_{i+n}(X)$ .

# A knot Floer stable homotopy type

To each grid diagram  $\mathbb{G}$  and integer  $j$  we will associate a suspension spectrum  $\mathcal{X}_j^+(\mathbb{G})$  such that

$$\tilde{H}_i(\mathcal{X}_j^+(\mathbb{G}); \mathbb{Z}) = GH_{i,j}^+(\mathbb{G}).$$

Just as  $GH^+$  comes equipped with the structure of a module over the polynomial ring  $\mathbb{Z}[U_1, \dots, U_n]$ , here we have maps

$$U_i : \mathcal{X}_j^+(\mathbb{G}) \rightarrow \Sigma^2 \mathcal{X}_{j-1}^+(\mathbb{G}),$$

where  $\Sigma^2$  denotes the double suspension.

**Caveat:** We haven't proved that  $\mathcal{X}_j^+(\mathbb{G})$  is a knot invariant, but we expect it to be so.

# An example: $T(2, 5)$

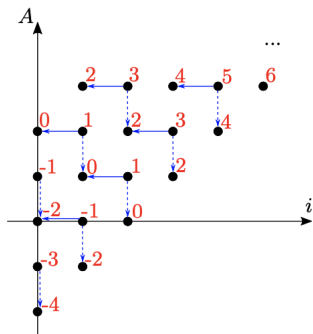

$CFK^+(T(2, 5))$

In gradings  $A = j \neq 1$ , the grid homology  $GH_j^+$  is supported in at most two consecutive gradings  $\Rightarrow \mathcal{X}_j^+$  is a wedge of spheres; e.g.  $\mathcal{X}_{-1}^+ = S^{-3} \vee S^{-2}$ .

When  $j = 1$ , the spectrum  $\mathcal{X}_{-1}^+$  has two cells in dimensions  $-1$  and  $2$ , attached via a map  $\tau : S^1 \rightarrow S^{-1}$ . There are two possibilities, according to  $[\tau] \in \pi_2^{st}(S^0) = \mathbb{Z}/2$ .

We expect that  $[\tau] = 0$ , and therefore  $\mathcal{X}_1^+ = S^{-1} \vee S^2$ .

1. We can do similar constructions for other versions of grid homology ( $\widehat{GH}$ ,  $GH^-$ , ...) provided we don't allow the domains of pseudo-holomorphic strips to cross a particular  $X$ -marking on the grid.
2. The construction of  $\mathcal{X}_j^+(\mathbb{G})$  is based on *framed flow categories* (**Cohen-Jones-Segal**, 1995) and similar in spirit to the construction of *Khovanov stable homotopy types* by **Lipshitz-Sarkar** (2011).
3. We will need to talk about “bubbles” in the construction, even for the version  $\mathcal{X}^+(\mathbb{G})$  where in holomorphic geometry we don't have bubbles.

# Framed flow categories

To upgrade a chain complex  $C_*$  to a suspension spectrum, we need a *framed flow category* (cf. **Cohen-Jones-Segal**):

**Objects** = generators of  $C_*$

**Morphisms:**  $\text{Hom}(x, y) = \overline{\mathcal{M}}(x, y)$  a compact manifold with corners (in fact,  $\langle d \rangle$ -manifold) of dimension  $d = \text{gr}(x) - \text{gr}(y) - 1$ ; e.g. in Lagrangian  $HF$ , the compactified moduli space of holomorphic strips from  $x$  to  $y$ .

We require that

$$\partial \overline{\mathcal{M}}(x, y) = \coprod_z \overline{\mathcal{M}}(x, z) \times \overline{\mathcal{M}}(z, y)$$

- + neat embeddings of  $\overline{\mathcal{M}}(x, y)$  into suitable  $\mathbb{R}_+^k \times \mathbb{R}^m$
- + framings of their normal bundles
- + compatibility conditions.

# From framed flow categories to spectra

From a framed flow category we get a spectrum  $\mathcal{X}$  by attaching one  $d$ -dimensional cell for each generator in degree  $d$ .

The spaces  $\overline{\mathcal{M}}(x, y)$  tell us the attaching maps, via the Pontryagin-Thom construction.

**Example:** Say we have two generators  $y$  and  $x$  in degrees  $a < b$ . Let  $k = b - a - 1$ . Then  $\mathcal{X}$  is obtained from  $S^a$  by attaching a  $b$ -cell via a stable map

$$\tau : S^{b-1} \rightarrow S^a, \quad [\tau] \in \pi_k^{st}(S^0) \cong \Omega_{fr}^k$$

where  $\Omega_{fr}^k$  is the framed cobordism group.

The stably framed manifold  $\overline{\mathcal{M}}(x, y)$  gives the desired element in  $\Omega_{fr}^k$ .



# A framed flow category for $GC_j^+$

To do this for the grid complex  $GC_j^+$ , we need to construct manifolds with corners

$$\overline{\mathcal{M}}(U_1^{i_1} \dots U_n^{i_n} x, U_1^{j_1} \dots U_n^{j_n} y) = \overline{\mathcal{M}}(x, U_1^{j_1 - i_1} \dots U_n^{j_n - i_n} y)$$

We do this whenever there is a positive domain (sum of rectangles)  $D$  from  $x$  to  $y$  going over the  $O$  basepoints a specified number of times.

Two domains are *equivalent* if they differ by a periodic domain, i.e. a linear combination of (row – column going through the same  $O_j$ ).

We write  $\overline{\mathcal{M}}(x, U_1^{j_1} \dots U_n^{j_n} y) = \overline{\mathcal{M}}([D])$ , where  $[D]$  is an equivalence class of positive domains.

This is a model for the moduli space of pseudo-holomorphic strips in  $\text{Sym}^n(\mathbb{C})$  supported in domains in the class  $[D]$ .

# Structure of the moduli spaces

Fix generators  $x$  and  $U_1^{j_1} \dots U_n^{j_n} y$ ; let  $D_1, D_2, \dots, D_k$  be all the positive domains that connect them (not passing through the special  $X$  marking and passing through  $O_i$   $j_i$  times), and let  $[D]$  be their equivalence class. To apply Cohen-Jones-Segal construction, we need the following:

- $d$ -dimensional  $\langle d \rangle$ -manifold  $\overline{\mathcal{M}}([D])$  (where  $d = \mu([D]) - 1$ ), with  $\partial_i \overline{\mathcal{M}}([D])$  (the  $i$ -th portion of the boundary) identified with products  $\overline{\mathcal{M}}([E]) \times \overline{\mathcal{M}}([F])$  with  $[E] + [F] = [D]$  and  $\mu([E]) = i$ .
- Neat embeddings of these moduli spaces into suitable Euclidean spaces, and coherent framings of their normal bundles.

# Gluing smaller pieces of the moduli spaces

What we do is construct some moduli spaces of the individual domains,  $\overline{\mathcal{M}}(D_i)$ . We then glue them together to get the space we want,

$$\overline{\mathcal{M}}([D]) = \overline{\mathcal{M}}(D_1) \cup \overline{\mathcal{M}}(D_2) \cup \cdots \cup \overline{\mathcal{M}}(D_k).$$

There are several issues:

- We neither expect nor construct these individual pieces  $\overline{\mathcal{M}}(D_i)$  as manifolds with corners; rather they are Whitney stratified spaces, with the stratification coming from disk bubbling.
- In order to glue these pieces, we need to keep track of these stratifications; consequently we need to keep track of a larger collection of moduli spaces—moduli spaces of domains along with a collection of disk bubbles attached to them. These will be the spaces  $\overline{\mathcal{M}}_{\vec{N}, \vec{\lambda}}(D)$  from later in the talk.

# Example 1

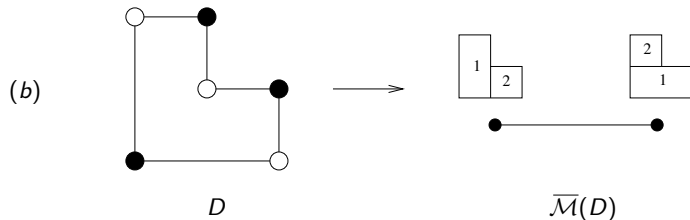
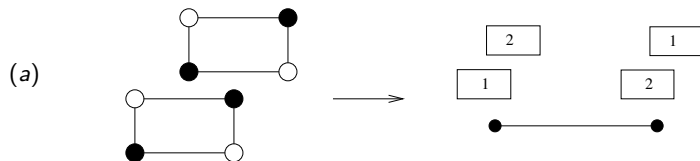

# Example 2

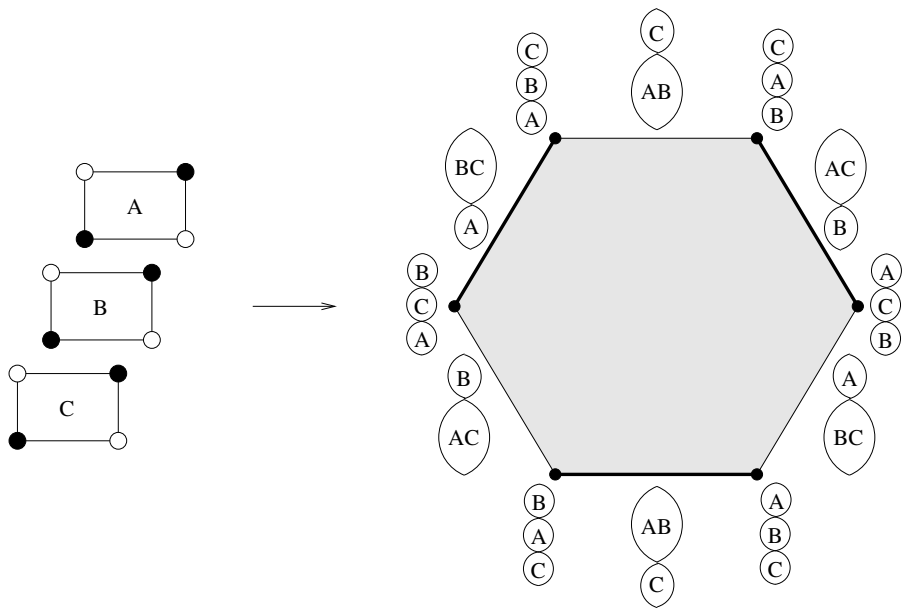

# Example 3

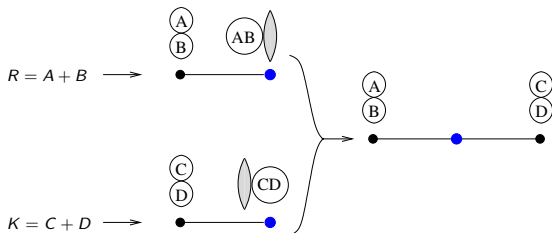
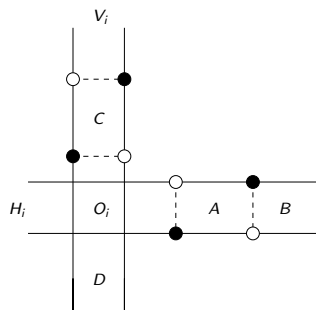

# Example 4

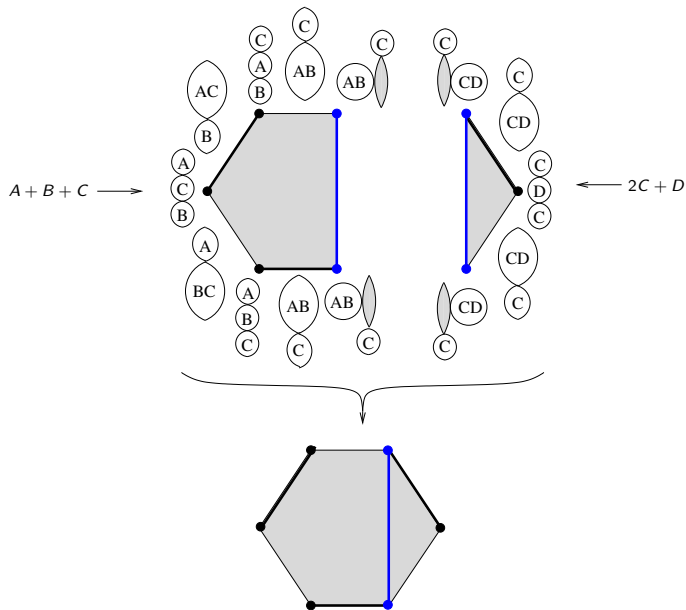

# Example 5 (Part 1 of 4)

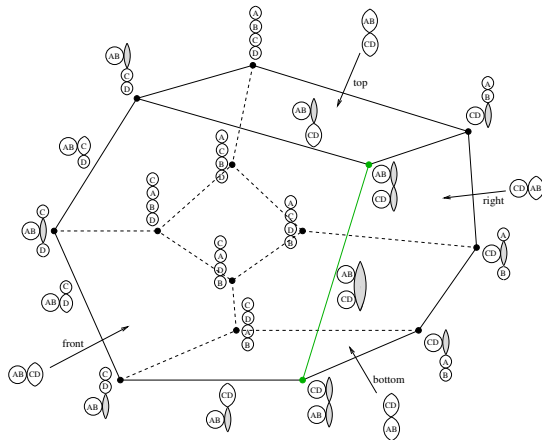
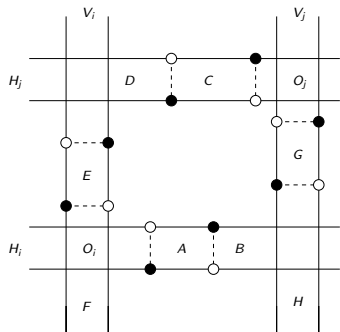



# Example 6 (Part 1 of 3)

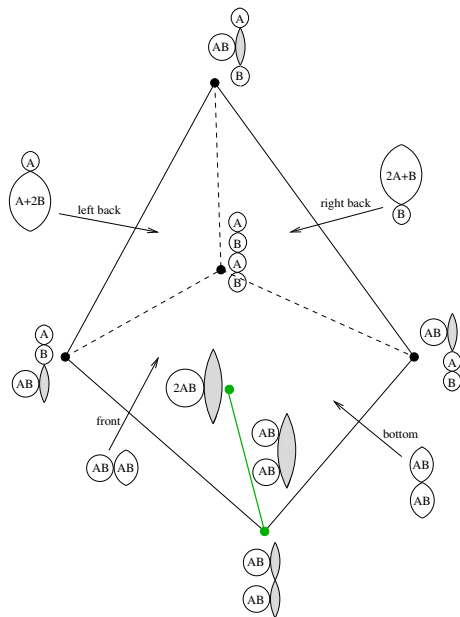
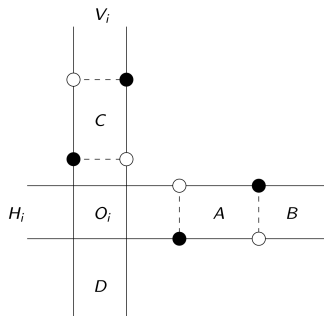

# Example 6 (Part 2 of 3)

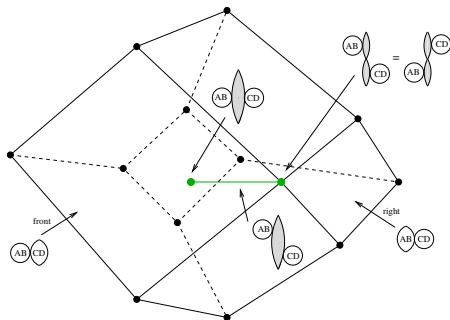
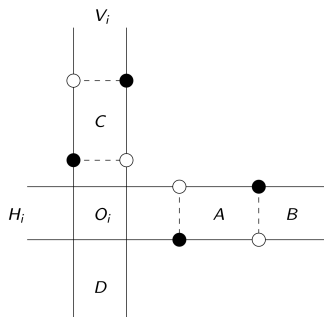

# The Whitney umbrella

In Example 6, the gluing is locally modeled on the decomposition of  $\mathbb{R}^3$  coming from the Whitney umbrella:

$$Z(2, 0, 0) = \{(a, b, c) \in \mathbb{R}^3 \mid a^2 b > c^2, c < 0\},$$

$$Z(1, 0, 1) = \{(a, b, c) \in \mathbb{R}^3 \mid a^2 b < c^2\},$$

$$Z(0, 0, 2) = \{(a, b, c) \in \mathbb{R}^3 \mid a^2 b > c^2, c > 0\},$$

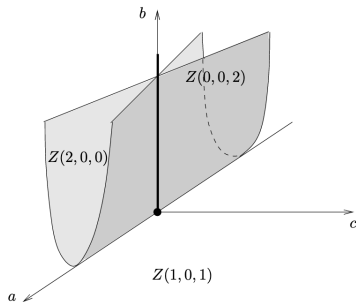

Consider

$$\mathrm{Sym}^N(\mathbb{C})/\mathbb{R} \cong \mathbb{C}^N/\mathbb{R} \cong \mathbb{R}^{2N-1}$$

This decomposes according to how many of the imaginary parts of

$$\{z_1, \dots, z_N\} \in \mathrm{Sym}^N(\mathbb{C})$$

are negative or positive (or zero).

When  $N = 2$ , we recover the Whitney umbrella decomposition of  $\mathbb{R}^3$ .

More generally, we will encounter these decompositions of  $\mathbb{R}^{2N-1}$  as local models for our stratified spaces.

# Construction of the moduli spaces

We will construct moduli spaces

$$\overline{\mathcal{M}}_{\vec{N}, \vec{\lambda}}(D)$$

which are models for the moduli spaces of pseudo-holomorphic strips with domain  $D$  and disk bubbles attached according to vectors

$$\vec{N} = (N_1, \dots, N_n), \quad \vec{\lambda} = (\lambda_1, \dots, \lambda_n)$$

Here  $N_j \in \mathbb{N}$ , and  $\lambda_j$  is an ordered partition of  $N_j$ . The number  $N_j$  counts the bubbles going through the  $j$ th  $O$ -marking. These bubbles are grouped according to the partition  $\lambda_j$ , with those in the same part appearing at the same height on the boundary of the pseudo-holomorphic strip.

The spaces  $\overline{\mathcal{M}}_{\vec{N}, \vec{\lambda}}(D)$  will have specified local models, and come equipped with *neat embeddings* in  $\mathbb{R}_+^k \times \mathbb{R}^m$  and with normal framings.

# Permutohedra

We first construct  $\overline{\mathcal{M}}_{\vec{N}, \vec{\lambda}}(D)$  when  $D = c_x$  (the trivial domain from some fixed  $x \in \mathbb{S}$  to itself), and all the entries of  $\vec{N}$  are 0's and 1's. In this case we define  $\overline{\mathcal{M}}_{\vec{N}, \vec{\lambda}}(D)$  to be the permutohedron  $P_n$ , and give it a normal framing:

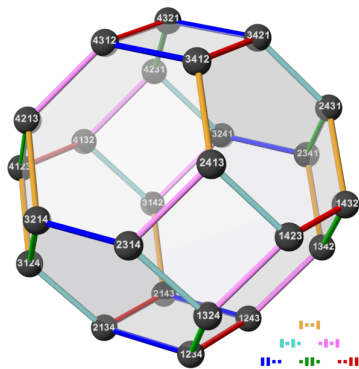

# The inductive argument

We define the rest of the spaces  $\overline{\mathcal{M}}_{\vec{N}, \vec{\lambda}}(D)$  inductively on their dimension  $k$ . For the base case  $k = 0$ , we define them to be points.

For the inductive step, we suppose all spaces up to dimension  $k$  have been constructed, along with their embeddings and normal framings.

To construct a  $(k + 1)$ -dimensional space  $\overline{\mathcal{M}}_{\vec{N}, \vec{\lambda}}(D)$ , we start with its (already constructed) boundary  $\partial \overline{\mathcal{M}}_{\vec{N}, \vec{\lambda}}(D)$  and smooth it to get a  $k$ -dimensional framed manifold  $\partial' \overline{\mathcal{M}}_{\vec{N}, \vec{\lambda}}(D)$ .

From here we get an element in the framed cobordism group

$$[\partial' \overline{\mathcal{M}}_{\vec{N}, \vec{\lambda}}(D)] \in \Omega_{\text{fr}}^k.$$

# The complex of positive domains with partitions

We define a complex  $CDP$  whose generators are “positive domains with partitions,” i.e., triples  $(D, \vec{N}, \vec{\lambda})$ , where  $D$  does not go over a specified  $X$ -marking. The differential  $\delta : CDP_k \rightarrow CDP_{k-1}$  has four kinds of terms, corresponding to different boundaries of  $\overline{\mathcal{M}}_{\vec{N}, \vec{\lambda}}(D)$ :

- **Type I** terms, given by subtracting a rectangle from  $D$ ;
- **Type II** terms, given by boundary degenerations, i.e., subtracting the row or the column through  $O_j$  from  $D$ , and at the same time increasing  $N_j$  by one, and changing  $\lambda_j$  accordingly; e.g.  $10 = 2 + 5 + 3 \rightarrow 11 = 2 + 5 + 1 + 3$ .
- **Type III** terms, given by combining two terms in one of the partitions  $\lambda_j$ ; e.g.  $10 = 2 + 5 + 3 \rightarrow 10 = 2 + 8$ . This corresponds to two bubbles reaching the same height.
- **Type IV** terms, given by dropping the first or final term in one of the partitions  $\lambda_j$ ; e.g.  $10 = 2 + 5 + 3 \rightarrow 7 = 2 + 5$ . This corresponds to removing a boundary degeneration, in the limit as its height goes to  $-\infty$  or  $+\infty$ .



# The complex of positive domains with partitions

## Proposition

*For a grid diagram  $\mathbb{G}$  of size  $n$ , the homology of  $CDP_*$  is isomorphic to  $\mathbb{Z}^{2^n}$ . Its rank in degree  $k$  is  $\binom{n}{k}$ .*

The homology is supported by the subcomplex  $CDP_*^\dagger \subset CDP_*$  the subcomplex generated by triples  $(c_x, \vec{N}, \vec{\lambda})$  where  $\vec{N}$  made only of 0's and 1's.

Let  $CDP'_* = CDP_*/CDP_*^\dagger$ .

## Proposition

*The complex  $CDP'$  is acyclic (has trivial homology).*

## Back to the construction

Altogether, the classes  $[\partial' \overline{\mathcal{M}}_{\vec{N}, \vec{\lambda}}(D)] \in \Omega_{\text{fr}}^k$  produce an obstruction class

$$\sigma_k \in \text{Hom}(CDP'_{k+1}, \Omega_{\text{fr}}^k), \quad \sigma_k(D, \vec{N}, \vec{\lambda}) = [\partial' \overline{\mathcal{M}}_{\vec{N}, \vec{\lambda}}(D)].$$

### Proposition

*The class  $\sigma_k$  is a cocycle.*

Since  $CDP'$  is acyclic, so is  $\text{Hom}(CDP'_{k+1}, \Omega_{\text{fr}}^k)$ . It follows that  $\sigma_k$  is the coboundary of some element  $\mathfrak{b} \in \text{Hom}(CDP'_k, \Omega_{\text{fr}}^k)$ .

We use  $\mathfrak{b}$  to adjust the definition of the  $k$ -dimensional moduli spaces that we previously constructed, so that all cocycles  $\sigma_k$  vanish. For this, we simply take disjoint unions with framed manifolds representing  $-\mathfrak{b}$ . (Note that do not change the definition of any moduli spaces of dimension  $k-1$  or lower.)

## Finishing the inductive step

Then  $\partial' \overline{\mathcal{M}}_{\vec{N}, \vec{\lambda}}(D)$  is framed null-cobordant. We fill it in arbitrarily to obtain the desired framed moduli space  $\overline{\mathcal{M}}_{\vec{N}, \vec{\lambda}}(D)$ , and continue with the induction.

**Observation:** It was essential that the complex  $CDP'$  be acyclic.

To arrange this:

- We had to avoid one  $X$ -marking;
- We had to first construct the moduli spaces for triples  $(D, \vec{N}, \vec{\lambda})$  where  $D = c_x$  and  $\vec{N}$  is made of 0's and 1's;
- We had to consider bubble configurations. Note that  $GC^+$  only involves domains that do not cross any  $X$ -marking, and therefore cannot contain a full row or column (so no bubbles). However, the analogue of  $CDP'$  where we avoid all  $X$ -markings has complicated homology.

- Prove that the stable homotopy type of  $\mathcal{X}_j^+(\mathbb{G})$  is a knot invariant;
- Construct versions going over all  $O$  and  $X$ -markings;
- Constructions using pseudo-holomorphic curves ( $\rightsquigarrow$  Heegaard Floer stable homotopy types);
- Non-trivial computations: ideally, examples where  $GH_j^+(K) = GH_j^+(K')$  but  $\mathcal{X}_j^+(K) \neq \mathcal{X}_j^+(K')$ ;
- An explicit formula for  $Sq^2$  in the theory + computer implementation;
- Non-trivial maps associated to cobordisms (like the Hopf map).